

RoHS

Pin #	SIGNAL NAME	DESCRIPTION	MATING SEQUENCE	REV.	EC#	DESCRIPTION	DATE	DRAWING	CHECKED	APPROVED
1	VBUS	POWER	SECOND	X0		NEW RELEASE	11/12'19	JANYZ		WZX
2	D-	USB 2.0 DIFFERENTIAL PAIR	THIRD							
3	D+	DIFFERENTIAL PAIR								
4	GND	GROUND FOR POWER RETURN	SECOND							
5	StdA_SSRX-	SUPERSPEED RECEIVER DIFFERENTIAL PAIR	LAST							
6	StdA_SSRX+	DIFFERENTIAL PAIR								
7	GND_DRAIN	GROUND FOR SIGNAL RETURN								
8	StdA_SSTX-	SUPERSPEED TRANSMITTER DIFFERENTIAL PAIR								
9	StdA_SSTX+	DIFFERENTIAL PAIR								
Shell	Shield	CONNECTOR METAL SHELL	FRIST							

NOTE:

- MATERIAL:
  - INSULATOR: SEE PART NO.
  - CONTACT: C5191
  - SHELL: SUS304
- ELECTRICAL CHARACTERISTICS:
  - CONTACT RESISTANCE: 30m Max
  - CONTACT CURRENT RATING: 1.5A
  - DIELECTRIC WITHSTANDING VOLTAGE: 500 V R.M.S.
  - INSULATION RESISTANCE 100 MEGOHMS M
  - OPERATING TEMPERATURE: -40°C ~ 85°C
  - RATE VOLTAGE: 30V DC
- MECHANICAL CHARACTERISTICS:
  - MATING FORCE: 10 N Min INITIAL; 8 N Min AFTER TEST
  - UNMATED FORCE: 35 N Max
  - DURABILITY: 1500 CYCLES
- PLATING
  - TERMINAL CONTACT: G/F(0.8u" Au) PLATING ON CONTACT AREA  
80u" MIN Matte Tin PLATED ON SOLDER AREA  
30u" MIN. Ni UNDERPLATED OVERALL
  - SHELL: 50u" MIN. NICKEL ALL OVER
- SALT SPRAY: 24H

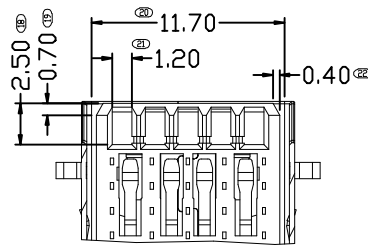
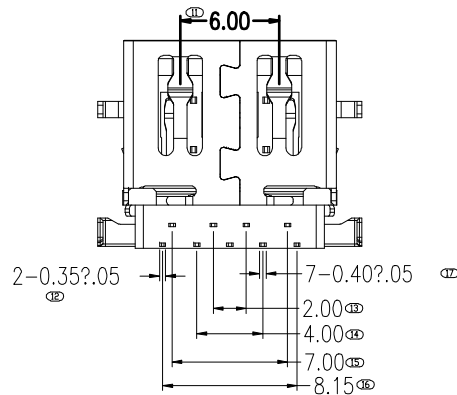
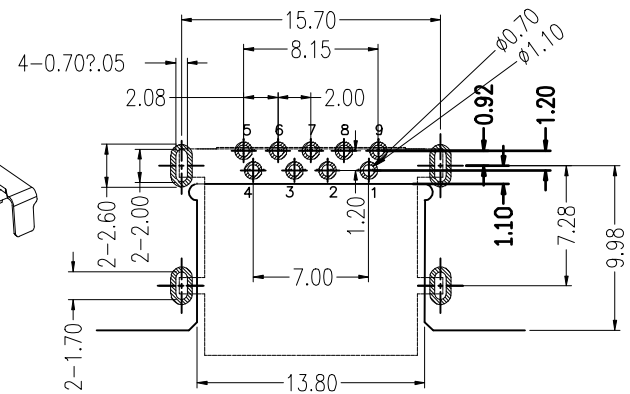
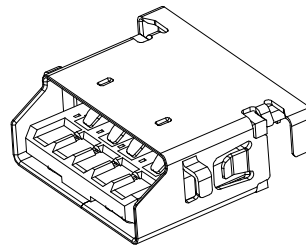
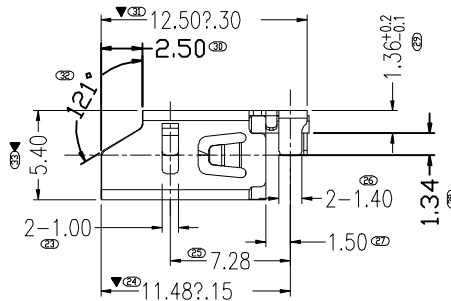
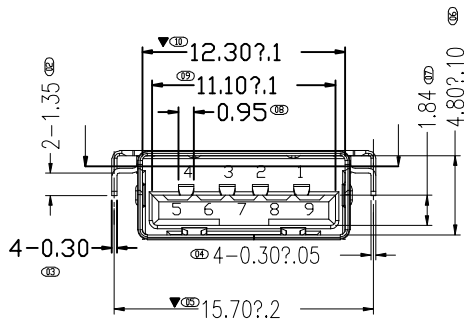
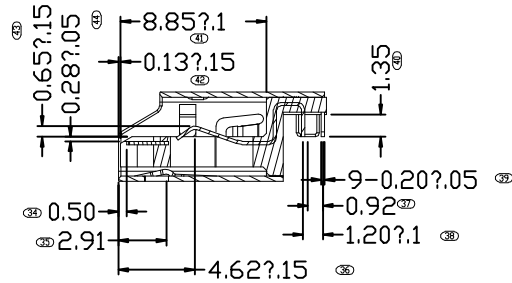
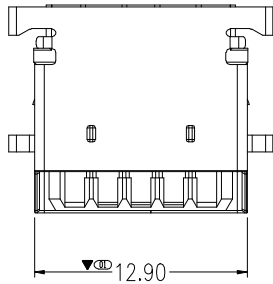

PAD AREA  
 KEEP OUT AREA  
 GND PATTERN ONLY

TOLERANCE: ±0.05, THICKNESS: 1.0~1.2mm  
**RECOMMENDED PCB LAYOUT**  
 (TOP VIEW)

MILLIMETERS	INCH	UNITS	东莞市溪榜电子有限公司			
X' ± 2'	X' ± 2'	MM	DONG GUAN XI BANG ELECTRONICS CO., LTD.			
.X ± 0.30	.XX ± 0.012	MAT'L	PART NUMBER:		TITLE:	
.XX ± 0.20	.XXX ± 0.008	SEE NOTES	XB-104013112		CUB06-110 USB3.0 塑料12.50 反壳1.30 接口四脚	
.XXX ± 0.10	.XXXX ± 0.004	FINISH	APPD:		DWG NO.:	
		SEE NOTES			C-104013112-00	
		QTY	CHKD:		SCALE SHEET REV.	
		SEE NOTES	DR:		1:1 1/2 XO	

RoHS

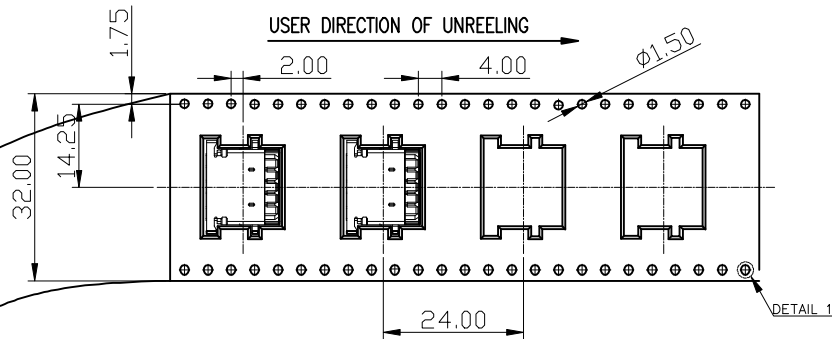

NOTES

1. NUMBER OF CONNECTORS: 400PCS/REEL
2. LEAD TAPE LENGTH

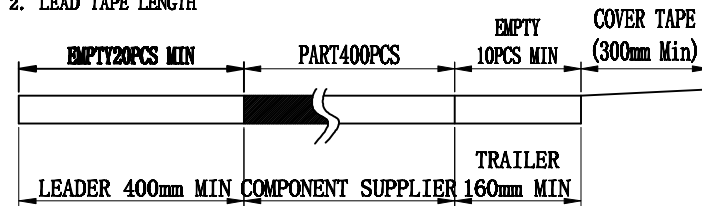

3. QUANTITY: 3200PCS/CARTON

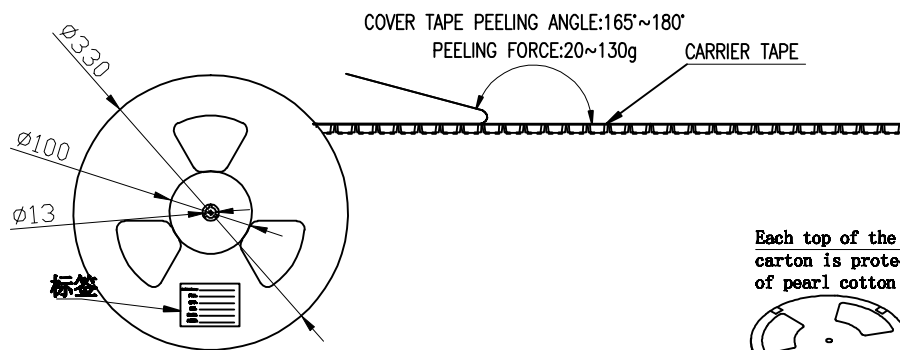

Each top of the bottom of the carton is protected by a piece of pearl cotton

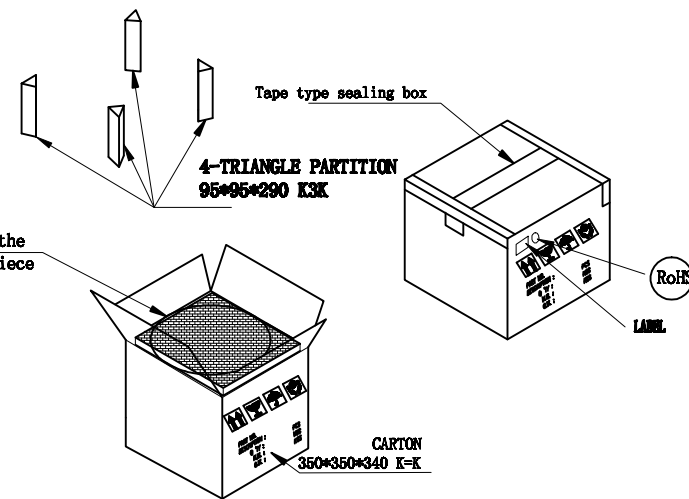
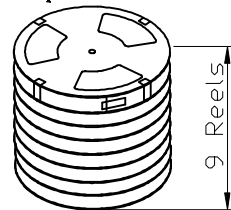

8 rolls per carton

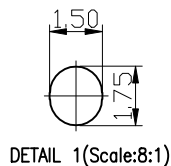
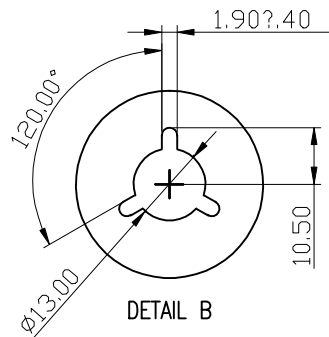

MILLIMETERS	INCH	UNITS	东莞市溪榜电子有限公司		
X. <sup>o</sup> ± 2'	X. <sup>o</sup> ± 2'	MM	DONG GUAN XI BANG ELECTRONICS CO., LTD.		
.X ± 0.30	.XX ± 0.012	MAT'L	PART NUMBER: XB-104013112		
.XX ± 0.20	.XXX ± 0.008	SEE NOTES	TITLE: (USB-110) USB 2.0 线材 12.50 长度 1.3 接口 四脚		
.XXX ± 0.10	.XXXX ± 0.004	FINISH	APPD: DWG NO.: C-104013112-00		
		SEE NOTES	CHKD:		
		QTY	DR:		
		SEE NOTES	SCALE SHEET REV. 1:1 2/2 XO		