

REVISION A RoHS Compliant

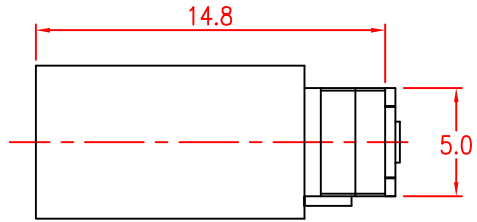

PART NO.	PIN DIA.
DS-305-13	1.3mm
DS-305-10	1.0mm
DS-305-16	1.6mm
DS-305-15	1.45mm

SYMB	REVISION	DATE	APVD.

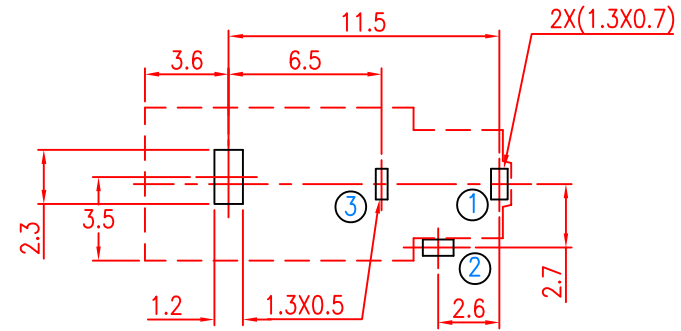
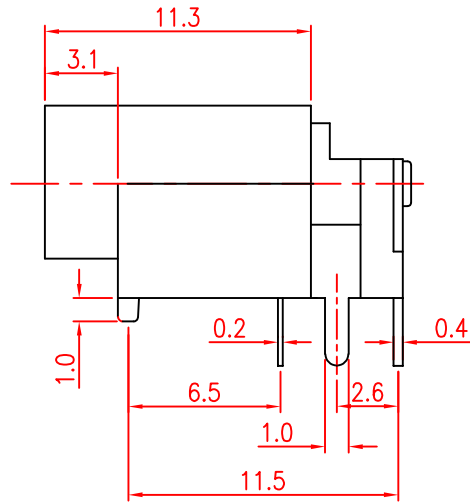
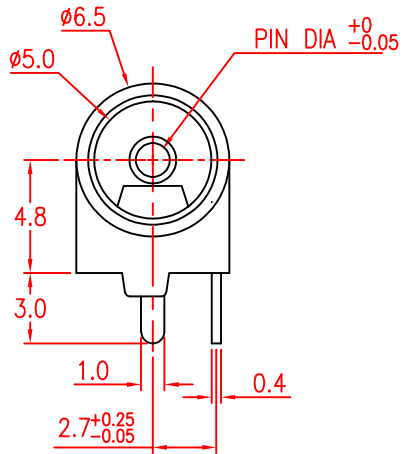

P.C.B LAYOUT
TOP VIEW

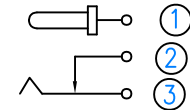
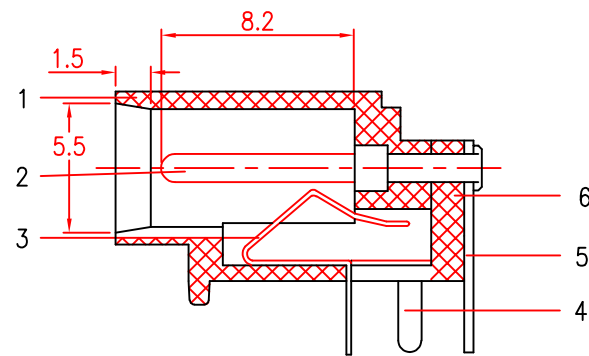
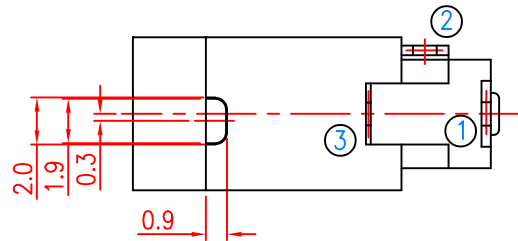
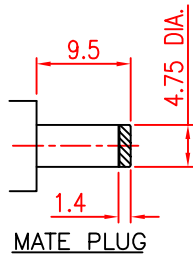

CIRCUIT

PIN DIA=1.6mm

TITLE	DC POWER JACK	DRAWN	L.Liu	TOLERANCE OTHERWISE UNLESS SPECIFIED	8				
PART NO.	XB-DS-305-16	CHECKED	G.C.Chen	UP TO 5	±0.2	7			
DRAW NO.	D75	APPROVED	H.K.Lai	ABOVE 5 ~ 30	±0.3	6	COVER	PA66	1 BLACK
				ABOVE 30 ~ 50	±0.4	5	PIN TERMINAL	BRASS STRIP	1 Ag PLATED
				ABOVE 50	±0.5	4	BREAK TERMINAL	BRASS STRIP	1 Ag PLATED
SCALE: 3:1	UNIT: mm	DATE: 21-09-2004		ANGLE	±3'	3	TIP TERMINAL	STAINLESS STEEL	1 Ag PLATED
						2	PIN	BRASS BAR	1 Ni PLATED
						1	HOUSING	PBT	1 BLACK
						NO.	PARTS	MATERIAL	QTY. FINISHING

东莞市溪榜电子有限公司
DONG GUAN XI BANG ELECTRONI CS CO., LTD.

Copyright Reserved, Please Do Not Copy.

版权所有, 不得翻印.