

CAD FILE:

ROHS

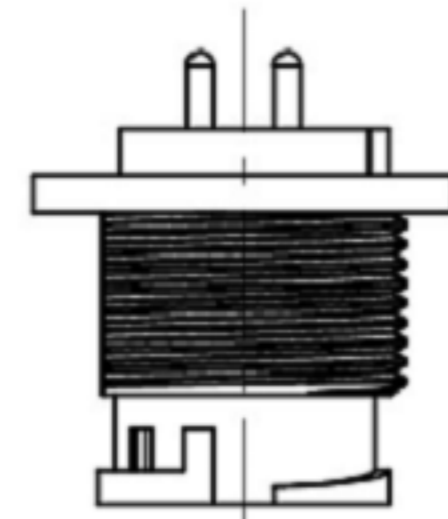
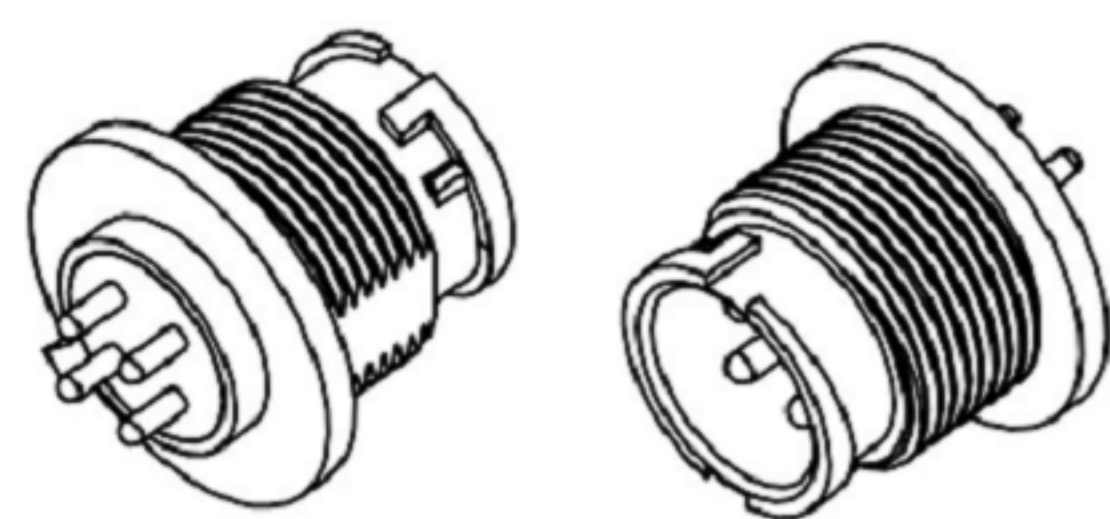

Nut Gasket

Accessories

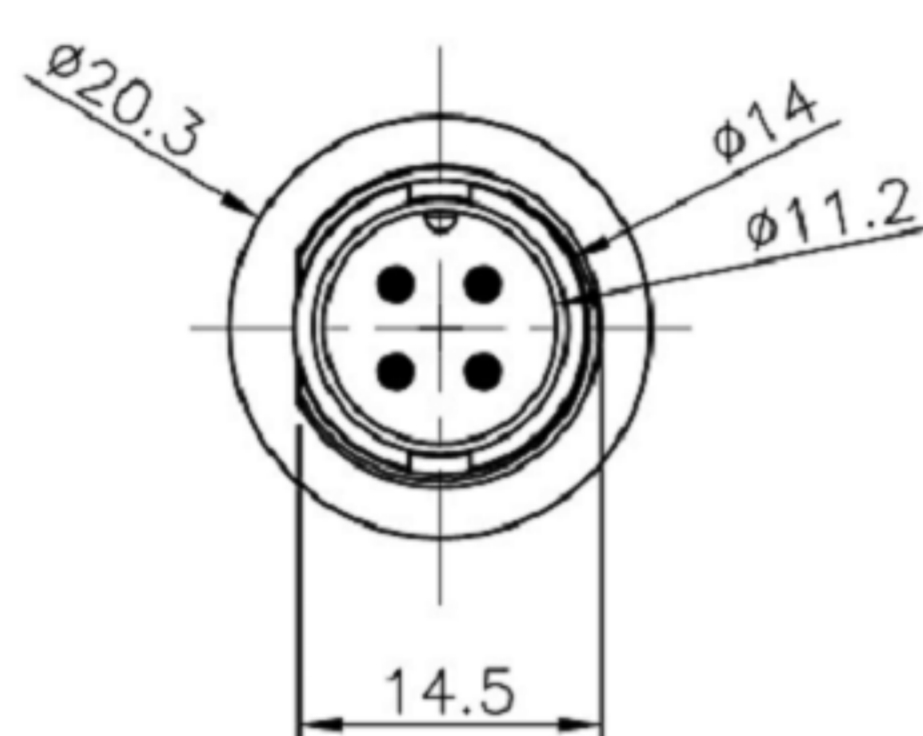
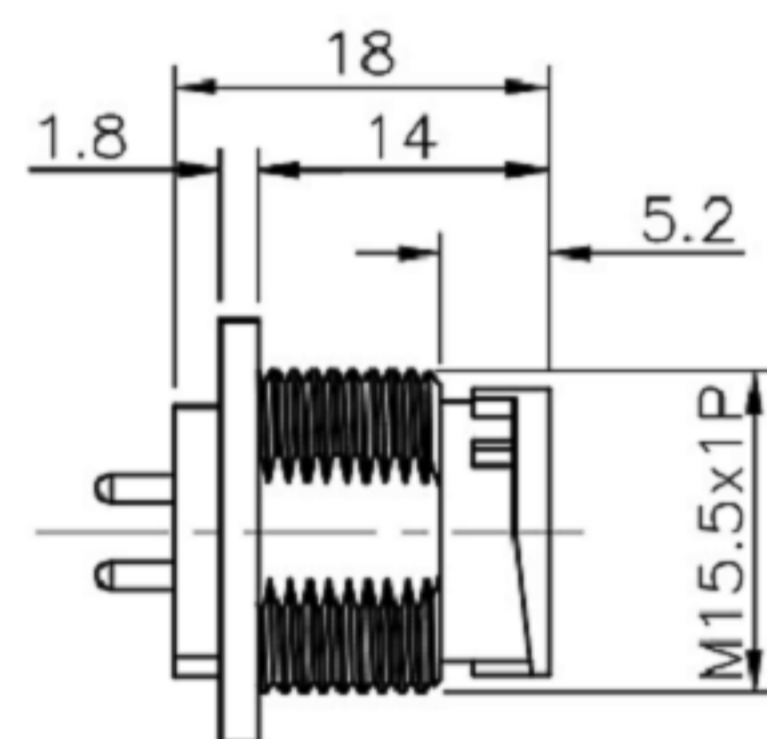

Body

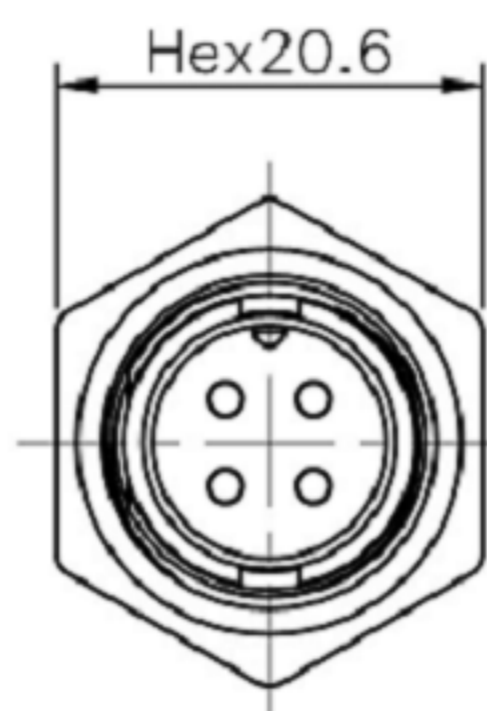

Assembly View

REV.	DESCRIPTION	DRAWN	DATE
1	INITIAL RELEASE	FROS	2020/06/10

SPECIFICATION:

1. Current Rating: 2A/ 5A/ 10A per pin (see P2. table)
2. Contact Resistance: 10mΩ
3. Insulation Resistance: 100MΩ
4. Dielectric Withstanding Voltage: 500VAC
5. Durability: 1000 Cycle
6. Operating temperature range: -40°C~+85°C
7. Storage temperature range: -40°C~+85°C
8. Water Proof: IP67

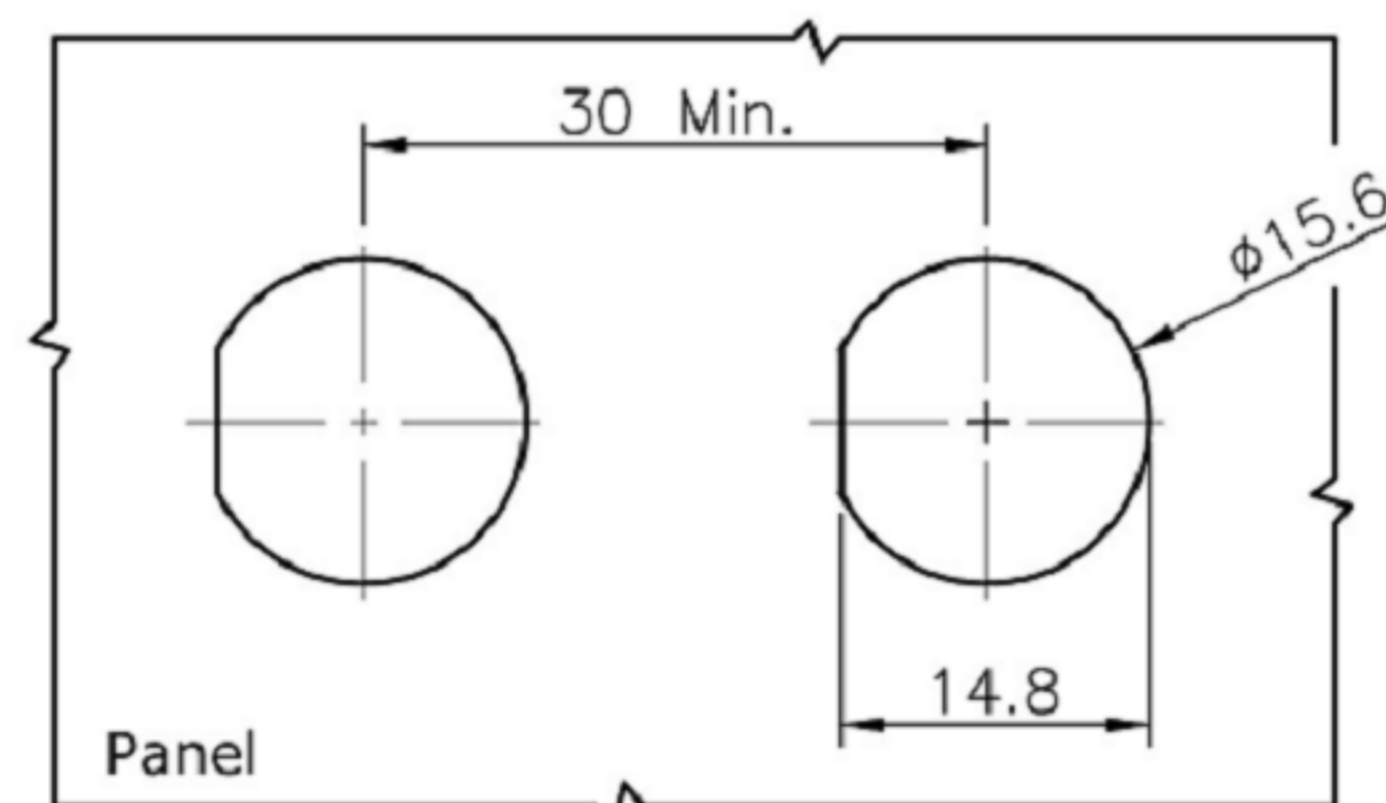
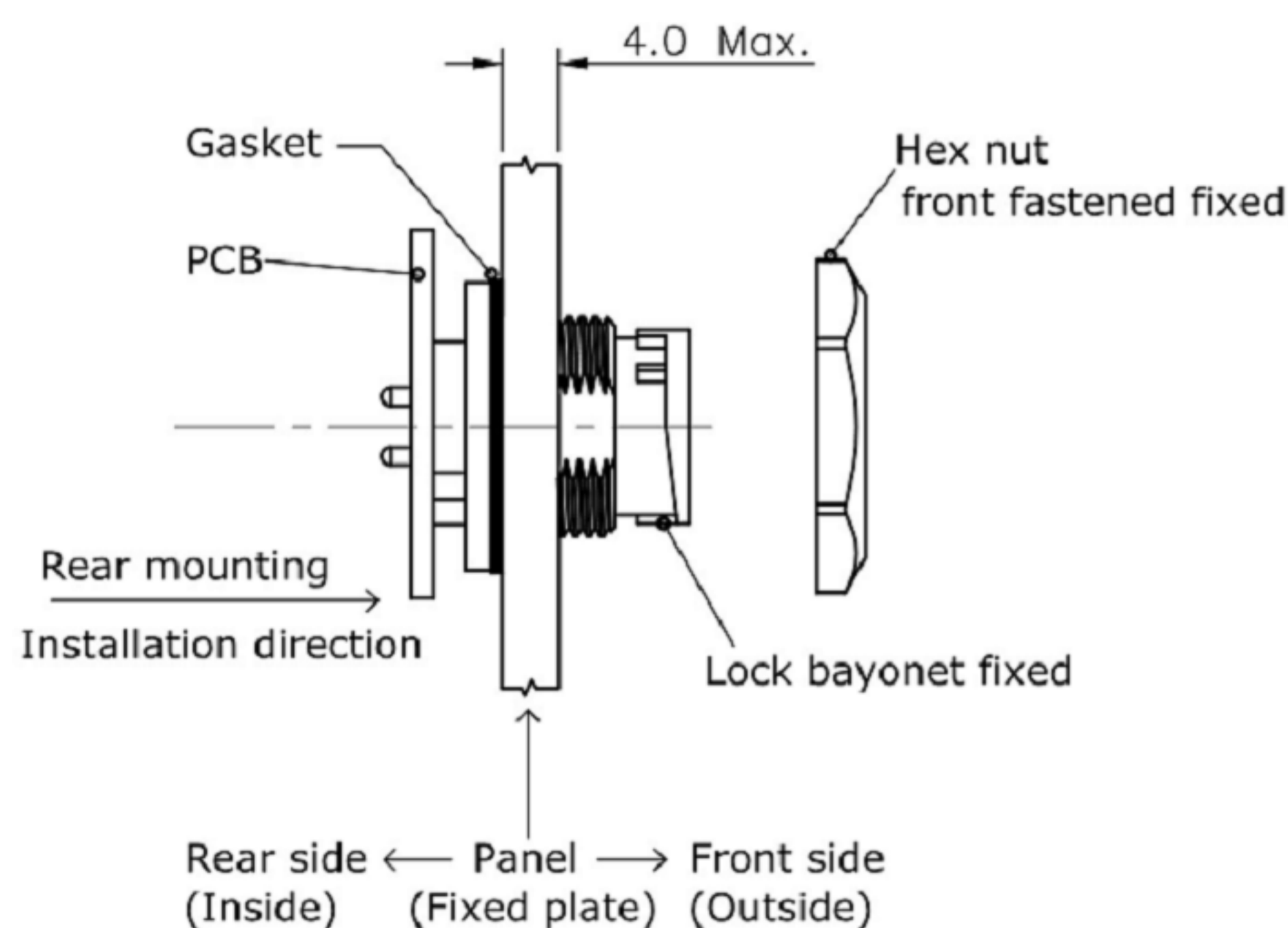
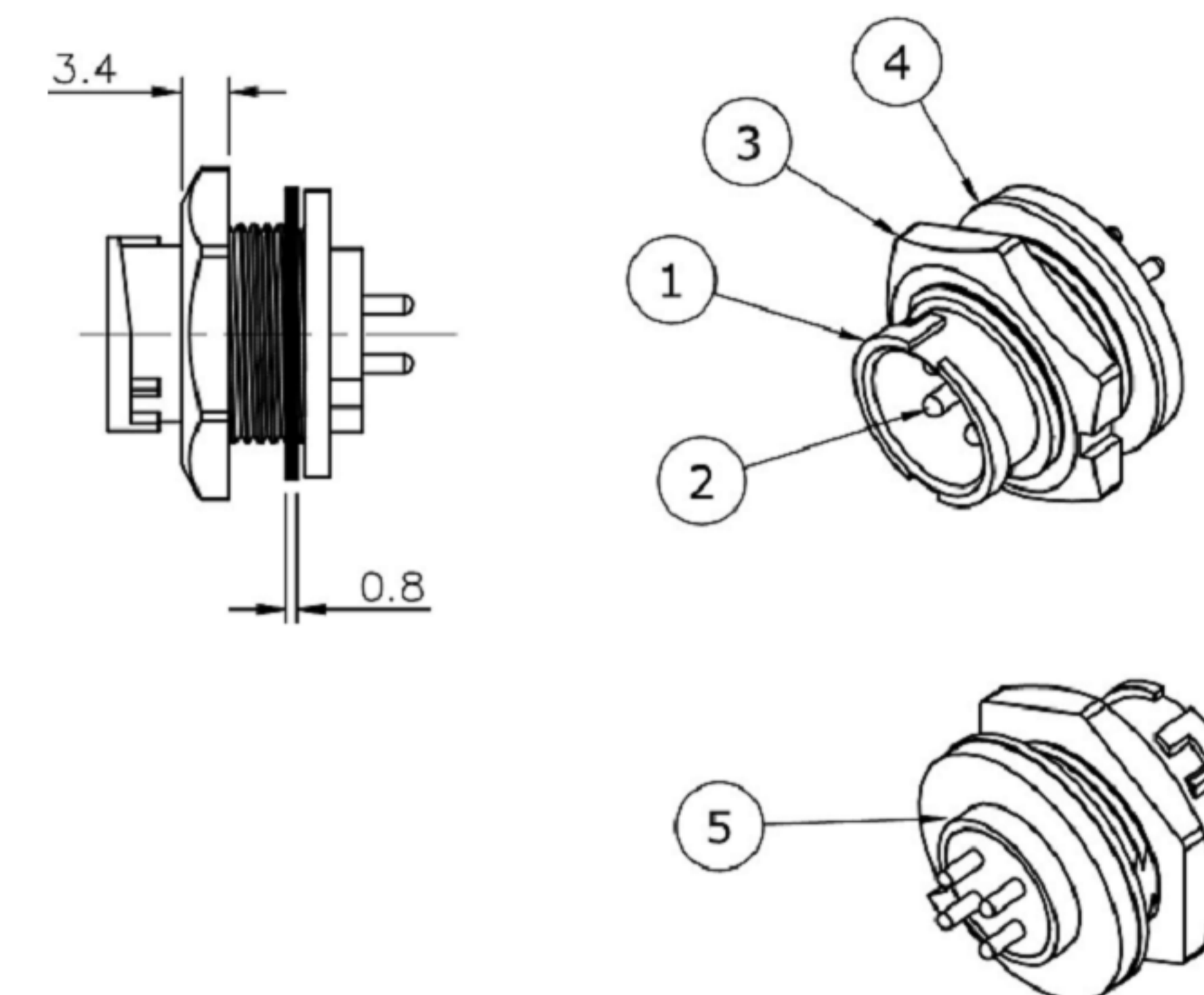

Recommend Panel Cut

5	GLUE	EPOXY
4	GASKET	Silicone, Gray
3	HEX NUT	PA66, UL94V-0, Black
2	CONTACT	Brass, 1u" Min. Gold Plating over Nickel
1	HOUSING	PA66, UL94V-0, Black
NO.	PART NAME	DESCRIPTION

NO.	PARTS	MATERIALS	Q'TY	FINISH	TOLERANCE UNLESS SPECIFIED	ISSUE	DATE	DESCRIPTIONS OF REVISION	APPD.
8									
7									
6					WITHIN 1.5mm : ±0.1mm	A	2012-9-25	初版	ZENQ. CHEN
5					OVER 1.5mm : ±0.2mm	ISSUE	DATE	DESCRIPTIONS OF REVISION	APPD.
4	CONTACT	SUS	1	Ag CLAD	TITLE : 圆形连接器			UNIT : mm	DRWG NO.: XB-227B-DMM0
3	CASE	PPA/BRASS SRTIP	1	BLACK/Ag PLATED	MODEL: Circular Connector			SCALE: 5:1	DWN. JUN. YANG 2012-9-25
2	COVER	STEEL STRIP	1	Ni PLATED	东莞市溪榜电子有限公司 DONG GUAN XI BANG ELECTRONICS CO., LTD.			CHK'D	DONG. PANG 2012-9-25
1	KNOB	PPA	1	BLACK				APPD.	ZENQ. CHEN 2012-9-25

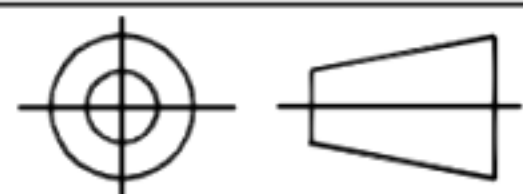

CAD FILE:

ROHS

REV.	DESCRIPTION	DRAWN	DATE
	SEE SHEET ONE		

TABLE: Pin Count/ Pin Assignment/ Current Rating/ Part Number

Part Number	227B-02M04	227B-03M05	227B-04M03	227B-05M02	227B-06M02	227B-07M01	227B-08M02
Pin Assignment							
Pin Count	2Pin	3Pin	4Pin	5Pin	6Pin	7Pin	8Pin
Current Rating	5A	5A	5A	5A	5A	5A	5A

Part Number	227B-02M03	227B-03M04	227B-04M02	227B-10M01	227B-12M01
Pin Assignment					
Pin Count	2Pin	3Pin	4Pin	10Pin	12Pin
Current Rating	10A	10A	10A	2A	2A

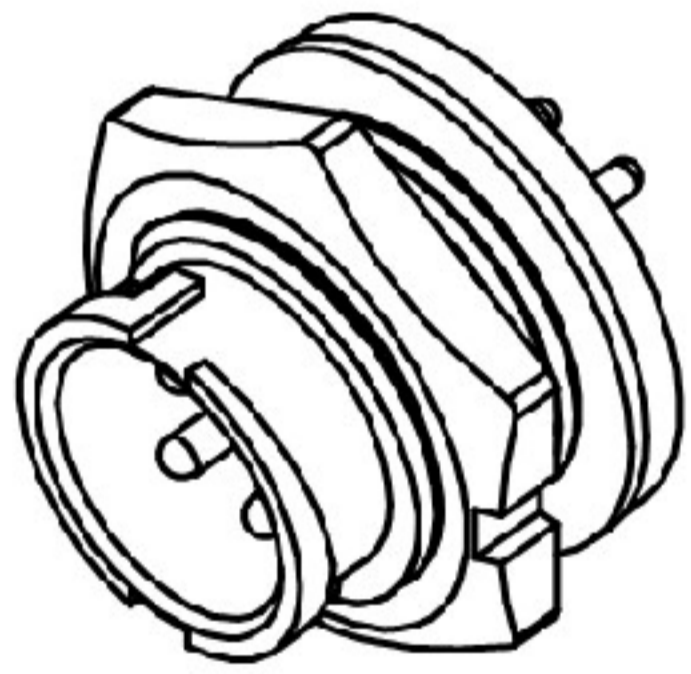

Drawing Number: 227B-DMM0
 Description: B size connector, panel fixed front fastened bayonet lock, male Socket male pin, DIP type

8					TOLERANCE UNLESS SPECIFIED						
7											
6					WITHIN 1.5mm : ±0.1mm	A	2012-9-25	初版		ZENQ. CHEN	
5					OVER 1.5mm : ±0.2mm	ISSUE	DATE	DESCRIPTIONS OF REVISION		APPD.	
4	CONTACT	SUS	1	Ag CLAD	TITLE : 圆形连接器			UNIT : mm	DRWG NO.: XB-227B-DMM0		
3	CASE	PPA/BRASS SRTIP	1	BLACK/Ag PLATED	MODEL: Circular Connector			SCALE: 5:1	DWN.	JUN. YANG	2012-9-25
2	COVER	STEEL STRIP	1	Ni PLATED	东莞市溪榜电子有限公司 DONG GUAN XI BANG ELECTRONICS CO., LTD.			CHK'D	DONG. PANG	2012-9-25	
1	KNOB	PPA	1	BLACK				APPD.	ZENQ. CHEN	2012-9-25	
NO.	PARTS	MATERIALS	Q'TY	FINISH							

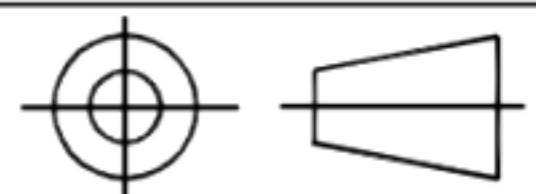

CAD FILE:

REV.	DESCRIPTION	DRAWN	DATE
	SEE SHEET ONE		

ROHS

Recommended layout (top view)

General tolerance: $\pm 0.05\text{mm}$

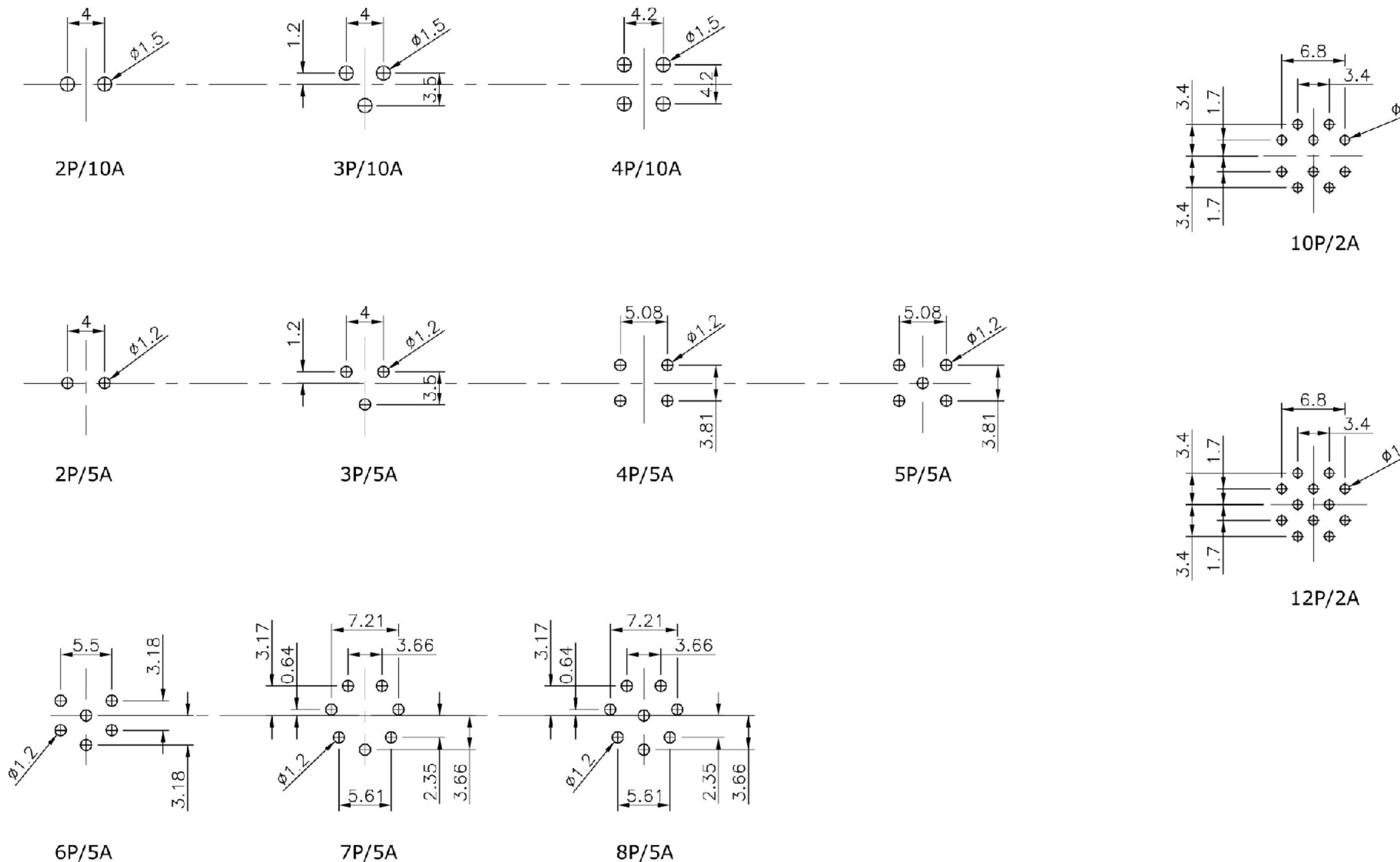

8					TOLERANCE						
7					UNLESS SPECIFIED						
6					WITHIN 1.5mm : $\pm 0.1\text{mm}$	A	2012-9-25	初版		ZENQ. CHEN	
5					OVER 1.5mm : $\pm 0.2\text{mm}$	ISSUE	DATE	DESCRIPTIONS OF REVISION		APPD.	
4	CONTACT	SUS	1	Ag CLAD	TITLE : 圆形连接器			UNIT : mm	DRWG NO.: XB-227B-DMM0		
3	CASE	PPA/BRASS SRTIP	1	BLACK/Ag PLATED	MODEL: Circular Connector			SCALE: 5:1	DWN.	JUN. YANG	2012-9-25
2	COVER	STEEL STRIP	1	Ni PLATED	东莞市溪榜电子有限公司 DONG GUAN XI BANG ELECTRONICS CO., LTD.			CHK'D	DONG. PANG	2012-9-25	
1	KNOB	PPA	1	BLACK				APPD.	ZENQ. CHEN	2012-9-25	
NO.	PARTS	MATERIALS	Q'TY	FINISH							

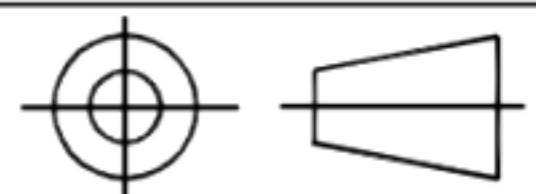

CAD FILE:

ROHS

REV.	DESCRIPTION	DRAWN	DATE
1	INITIAL RELEASE	FROS	2020/06/10

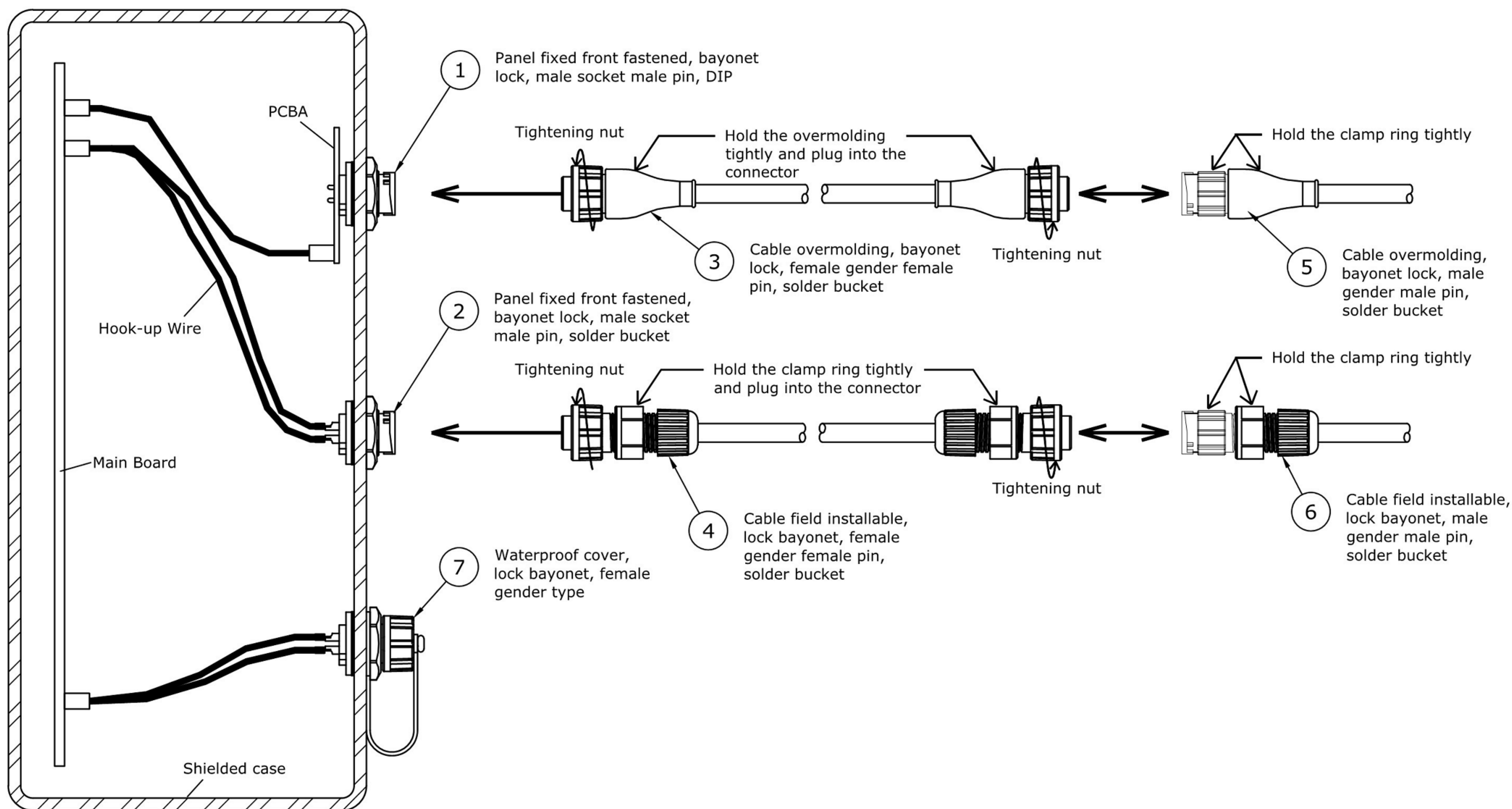

NO.	PARTS	MATERIALS	Q'TY	FINISH	TOLERANCE UNLESS SPECIFIED				
8					TOLERANCE UNLESS SPECIFIED				
7					TOLERANCE UNLESS SPECIFIED				
6					WITHIN 1.5mm : ±0.1mm	A	2012-9-25	初版	ZENQ. CHEN
5					OVER 1.5mm : ±0.2mm	ISSUE	DATE	DESCRIPTIONS OF REVISION	APPD.
4	CONTACT	SUS	1	Ag CLAD	TITLE : 圆形连接器			UNIT : mm	DRWG NO.: XB-227B-DMM0
3	CASE	PPA/BRASS SRTIP	1	BLACK/Ag PLATED	MODEL: Circular Connector			SCALE: 5:1	DWN. JUN. YANG 2012-9-25
2	COVER	STEEL STRIP	1	Ni PLATED	东莞市溪榜电子有限公司 DONG GUAN XI BANG ELECTRONICS CO., LTD.			CHK'D	DONG. PANG 2012-9-25
1	KNOB	PPA	1	BLACK				APPD.	ZENQ. CHEN 2012-9-25